

GÉNÉRATEUR DE VIDE

SÉRIE YV

sopra
pneumatic.com

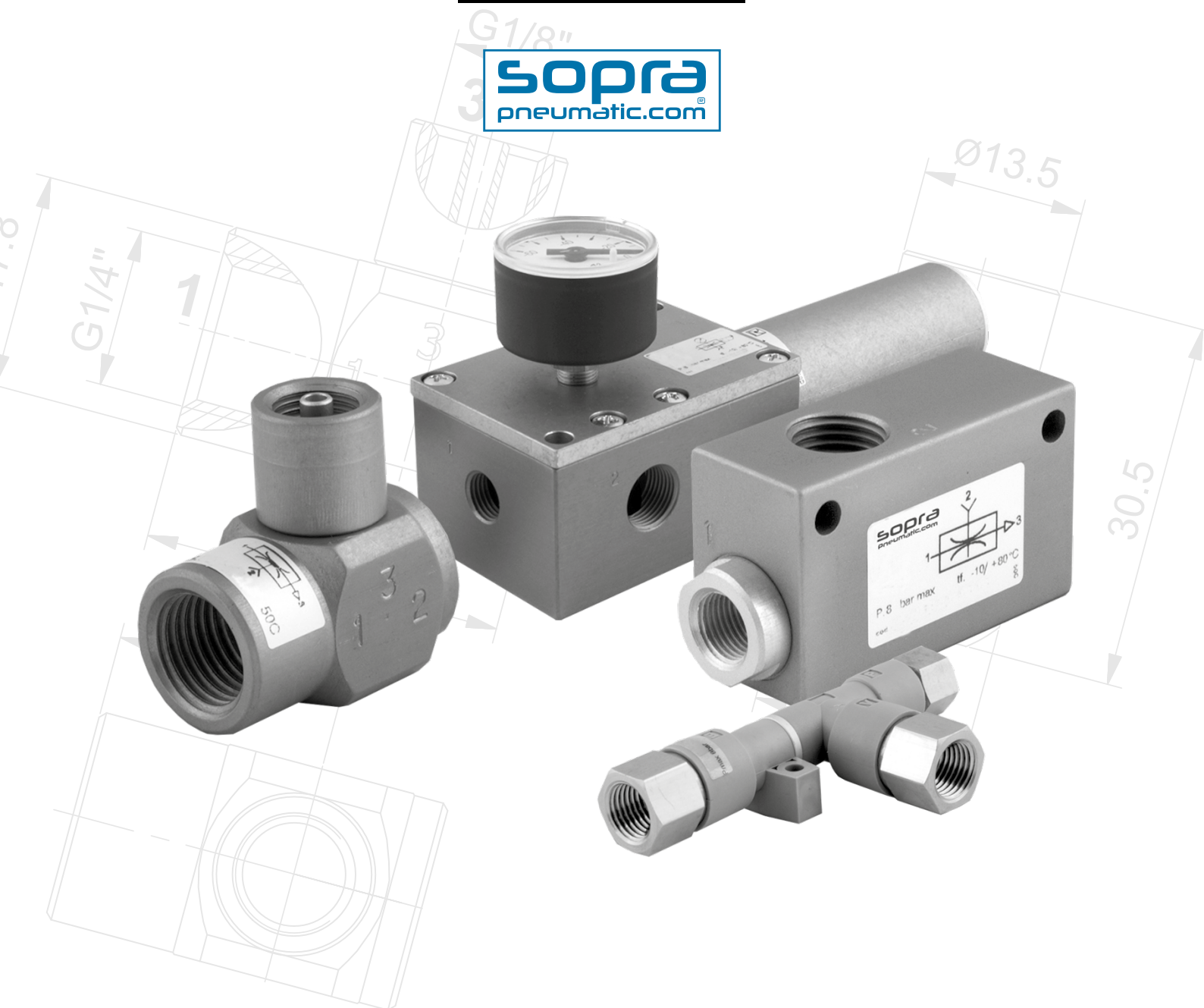

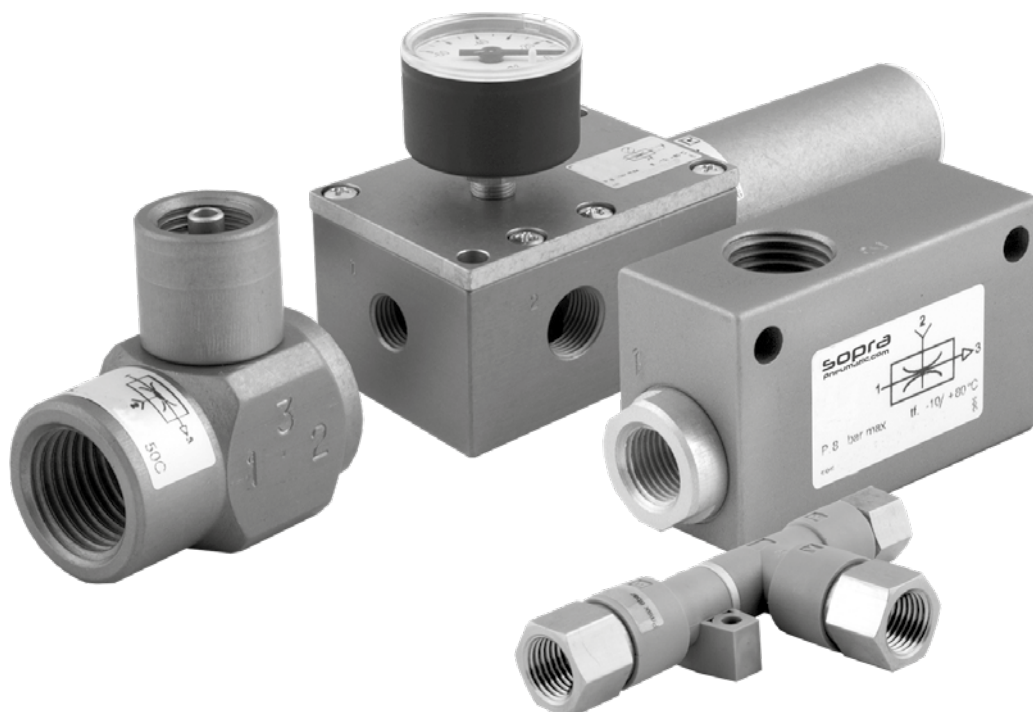

Y V 1 8 M 0 0 0 9 7 S E S

Série

Y : générateur de vide

Famille de produit

V : venturi

Orifice

M5 à 01

Type

MU : multi-étagé
MO : mono-étagé
MT : mono-étagé en T

Montage

S : silencieux

Option

CS : contre soufflage
SE : soufflage électrique

Débit

0097 : 97 NL/min

Caractéristiques	
Fluide	air filtré non lubrifié
Pression (bar)	1 à 8
Température (°C)	-10 à +80

YV.M5.M0.0007

GÉNÉRATEUR DE VIDE MONO-ÉTAGÉ
RACCORDEMENT M5

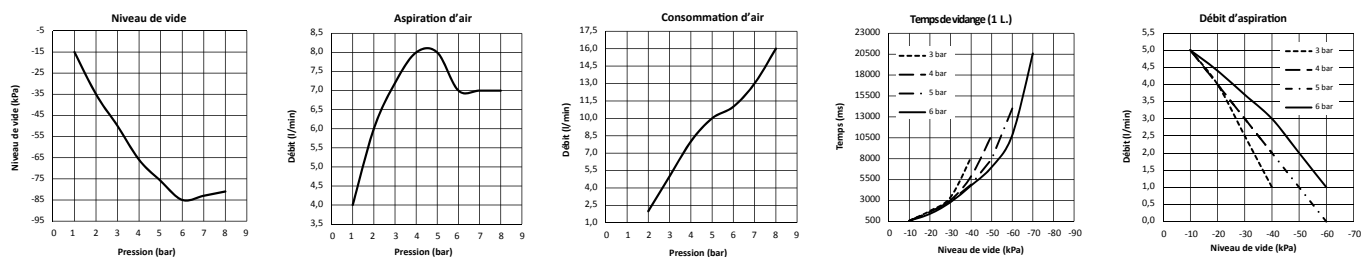
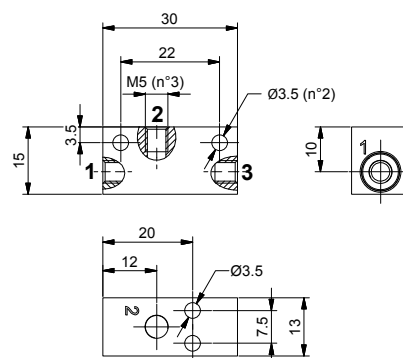

Caractéristiques			
Pression alimentation (bar)	2	4	6
Niveau de vide (Kpa)	-35	-66	-85
Capacité aspiration (l/min)	6	8	7
Consommation air (l/min)	2	8	11

Caractéristiques	
Fluide	air filtré non lubrifié
Pression (bar)	1 à 8
Température (°C)	-10 à +80
Poids (gr)	15

YV.M5.M0.0012

GÉNÉRATEUR DE VIDE MONO-ÉTAGÉ
RACCORDEMENT M5

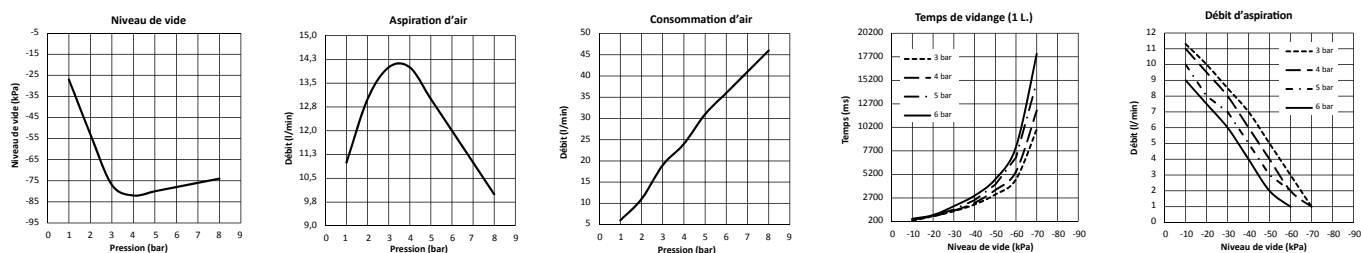
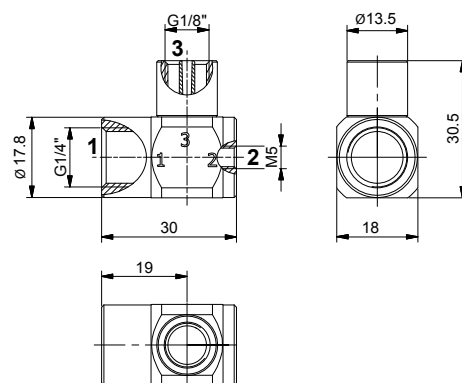

Caractéristiques			
Pression alimentation (bar)	2	4	6
Niveau de vide (Kpa)	-53	-82	-78
Capacité aspiration (l/min)	13	14	12
Consommation air (l/min)	11	24	36

Caractéristiques	
Fluide	air filtré non lubrifié
Pression (bar)	1 à 8
Température (°C)	-10 à +80
Poids (gr)	24

YV.18.M0.0012

GÉNÉRATEUR DE VIDE MONO-ÉTAGÉ
RACCORDEMENT G1/8"

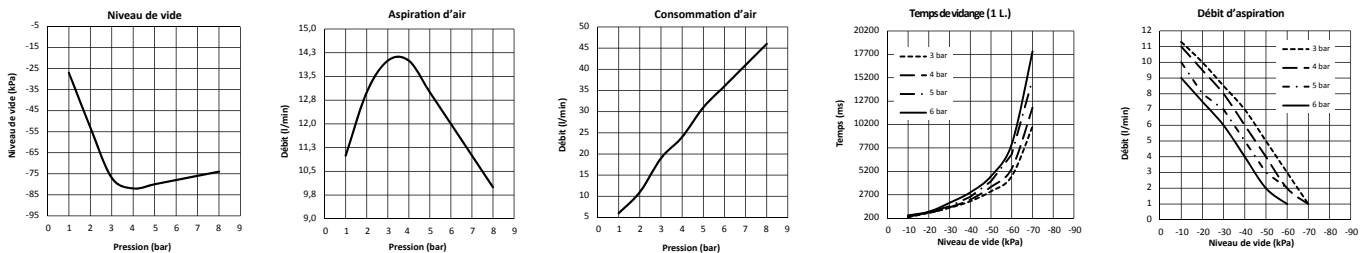
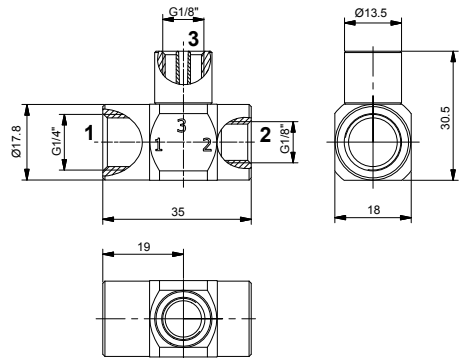

Caractéristiques			
Pression alimentation (bar)	2	4	6
Niveau de vide (Kpa)	-53	-82	-78
Capacité aspiration (l/min)	13	14	12
Consommation air (l/min)	11	24	36

Caractéristiques	
Fluide	air filtré non lubrifié
Pression (bar)	1 à 8
Température (°C)	-10 à +80
Poids (gr)	26

YV.14.M0.0012

GÉNÉRATEUR DE VIDE MONO-ÉTAGÉ
G1/4"

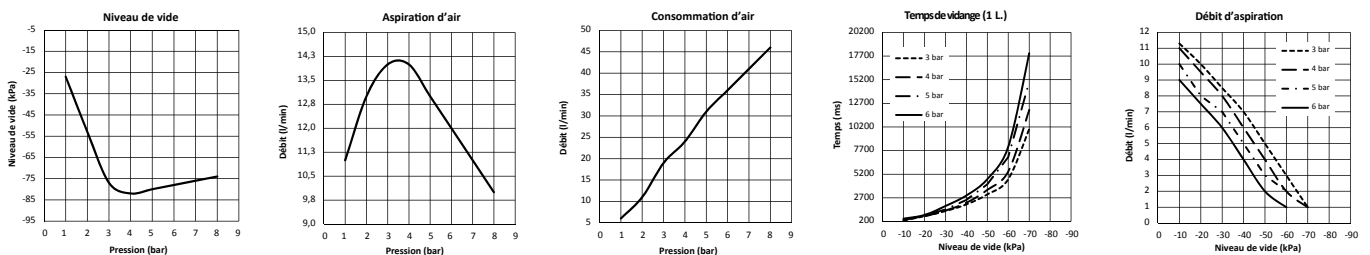
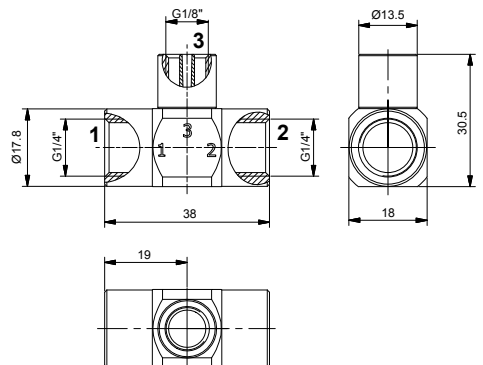

Caractéristiques			
Pression alimentation (bar)	2	4	6
Niveau de vide (Kpa)	-53	-82	-78
Capacité aspiration (l/min)	13	14	12
Consommation air (l/min)	11	24	36

Caractéristiques	
Fluide	air filtré non lubrifié
Pression (bar)	1 à 8
Température (°C)	-10 à +80
Poids (gr)	26

YV.14.M0.0034.CS

GÉNÉRATEUR DE VIDE MONO-ÉTAGÉ
RACCORDEMENT M5
CONTRE-SOUFFLAGE

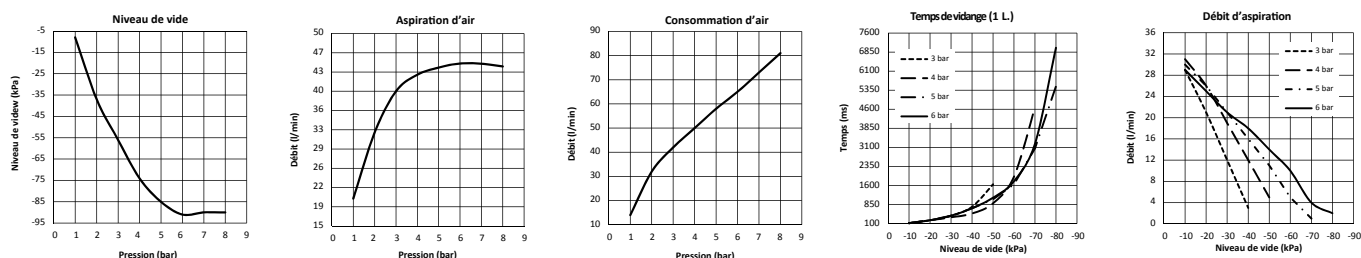
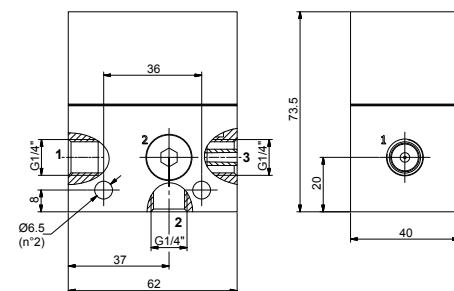

Caractéristiques			
Pression alimentation (bar)	2	4	6
Niveau de vide (Kpa)	-25	-60	-91
Capacité aspiration (l/min)	26	38	34
Consommation air (l/min)	25	45	63

Caractéristiques	
Fluide	air filtré non lubrifié
Pression (bar)	1 à 8
Température (°C)	-10 à +80
Poids (gr)	346

YV.14.M0.0035

GÉNÉRATEUR DE VIDE MONO-ÉTAGÉ
RACCORDEMENT G1/4"

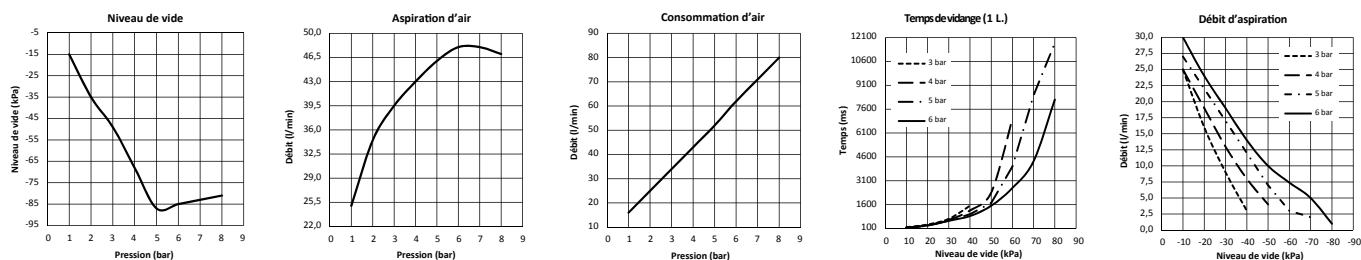
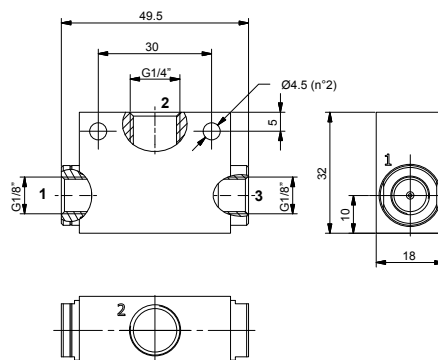

Caractéristiques			
Pression alimentation (bar)	2	4	6
Niveau de vide (Kpa)	-35	-68	-85
Capacité aspiration (l/min)	29	35	35
Consommation air (l/min)	25	43	62

Caractéristiques	
Fluide	air filtré non lubrifié
Pression (bar)	1 à 8
Température (°C)	-10 à +80
Poids (gr)	55

YV.14.M0.0040

GÉNÉRATEUR DE VIDE MONO-ÉTAGÉ
RACCORDEMENT G1/4"

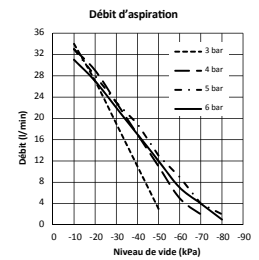
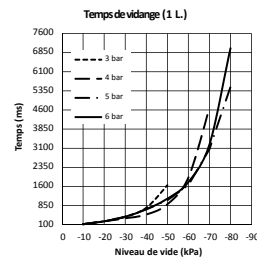
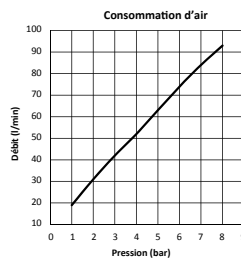
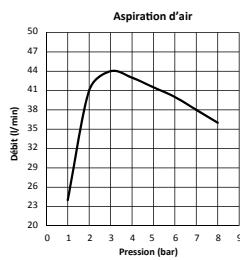
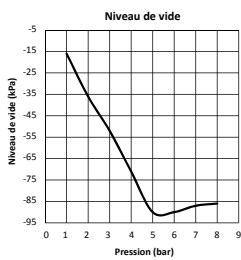
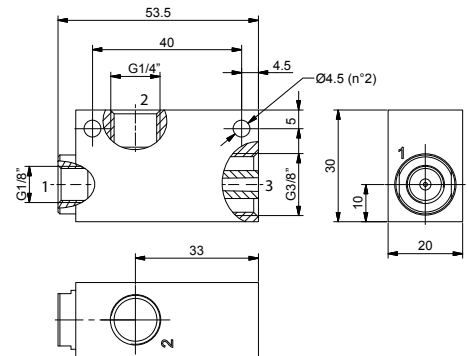

Caractéristiques			
Pression alimentation (bar)	2	4	6
Niveau de vide (Kpa)	-36	-71	-90
Capacité aspiration (l/min)	41	43	40
Consommation air (l/min)	31	52	74

Caractéristiques	
Fluide	air filtré non lubrifié
Pression (bar)	1 à 8
Température (°C)	-10 à +80
Poids (gr)	67

YV.14.M0.0034.CS+S

GÉNÉRATEUR DE VIDE MONO-ÉTAGÉ
RACCORDEMENT G1/4"
CONTRE-SOUFFLAGE ET SILENCIEUX

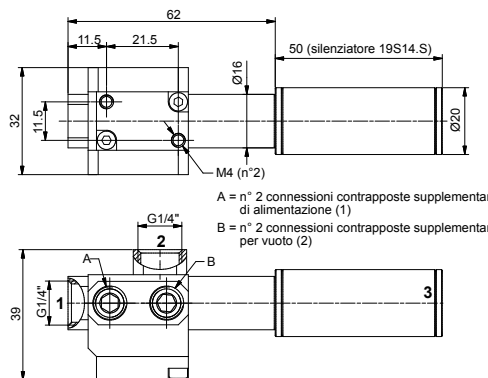

A = n° 2 connessioni contrapposte supplementari di alimentazione (1)
B = n° 2 connessioni contrapposte supplementari per vuoto (2)

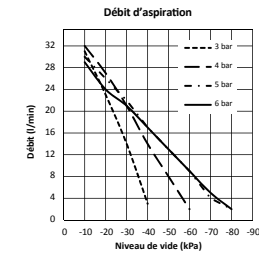
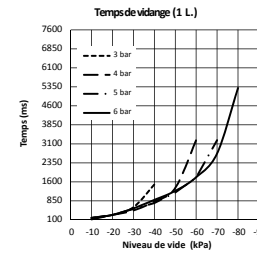
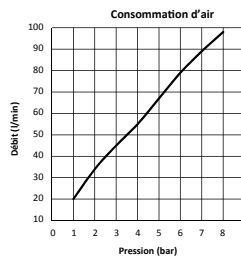
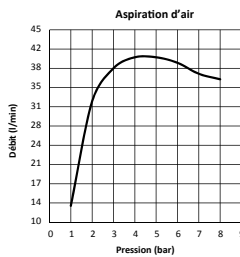
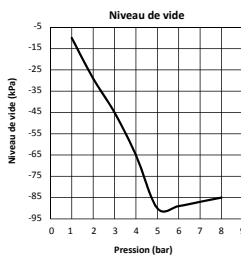

Caractéristiques			
Pression alimentation (bar)	2	4	6
Niveau de vide (Kpa)	-29	-65	-89
Capacité aspiration (l/min)	32	40	39
Consommation air (l/min)	34	55	79

Caractéristiques	
Fluide	air filtré non lubrifié
Pression (bar)	1 à 8
Température (°C)	-10 à +80
Poids (gr)	83

Générateurs de vide | SÉRIE YV

YV.14.M0.0057

GÉNÉRATEUR DE VIDE MONO-ÉTAGÉ
RACCORDEMENT G1/4"

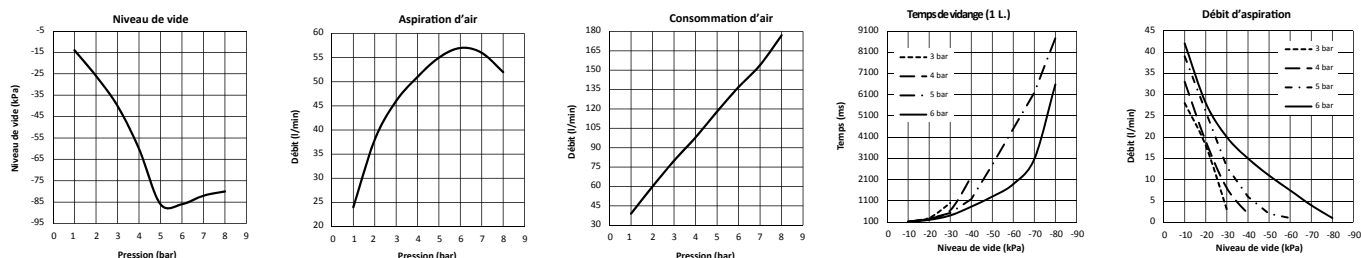
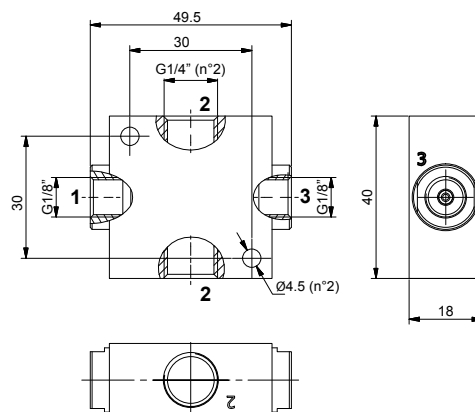

Caractéristiques				Caractéristiques	
Pression alimentation (bar)	2	4	6	Fluide	air filtré non lubrifié
Niveau de vide (Kpa)	-26	-60	-86	Pression (bar)	1 à 8
Capacité aspiration (l/min)	38	51	57	Température (°C)	-10 à +80
Consommation air (l/min)	60	98	137	Poids (gr)	68

YV.14.M0.0066.CS.S

GÉNÉRATEUR DE VIDE MONO-ÉTAGÉ
RACCORDEMENT G1/4"
CONTRE-SOUFFLAGE ET SILENCIEUX

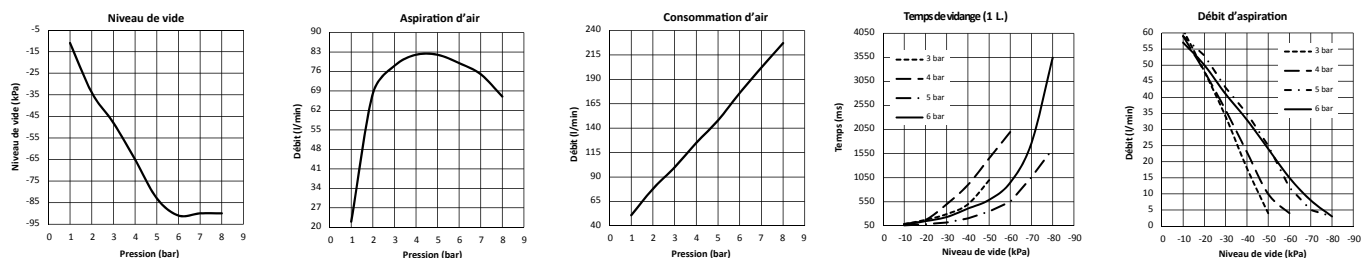
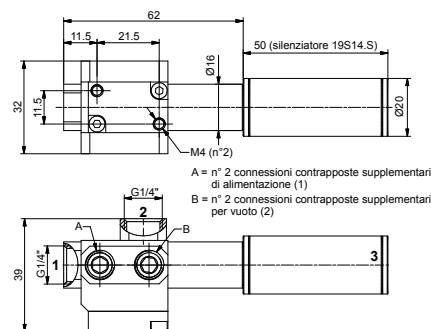

Caractéristiques				Caractéristiques	
Pression alimentation (bar)	2	4	6	Fluide	air filtré non lubrifié
Niveau de vide (Kpa)	-34	-65	-91	Pression (bar)	1 à 8
Capacité aspiration (l/min)	68	82	79	Température (°C)	-10 à +80
Consommation air (l/min)	78	125	176	Poids (gr)	83

Générateurs de vide | SÉRIE YV

YV.14.M0.0080.CS

GÉNÉRATEUR DE VIDE MONO-ÉTAGÉ
RACCORDEMENT G1/4"
CONTRE-SOUFFLAGE

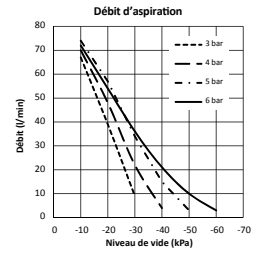
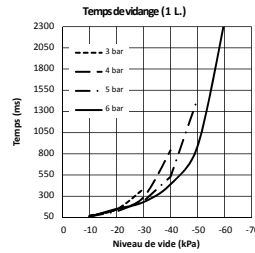
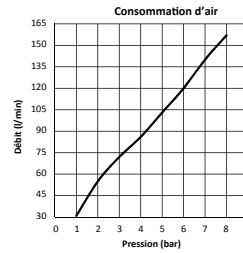
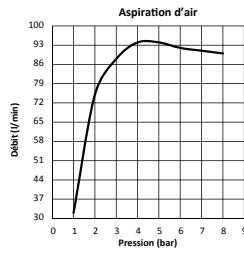
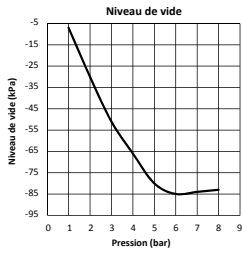
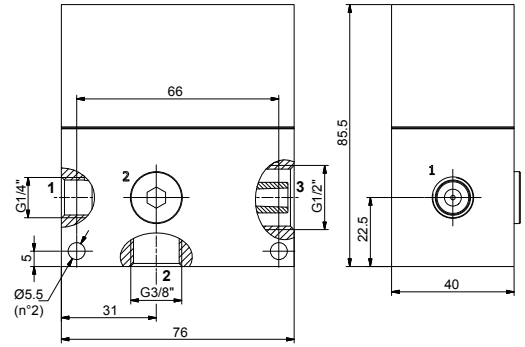

Caractéristiques			
Pression alimentation (bar)	2	4	6
Niveau de vide (Kpa)	-21	-45	-66
Capacité aspiration (l/min)	64	84	80
Consommation air (l/min)	48	83	120

Caractéristiques	
Fluide	air filtré non lubrifié
Pression (bar)	1 à 8
Température (°C)	-10 à +80
Poids (gr)	480

YV.38.M0.0074

GÉNÉRATEUR DE VIDE MONO-ÉTAGÉ
RACCORDEMENT G3/8"

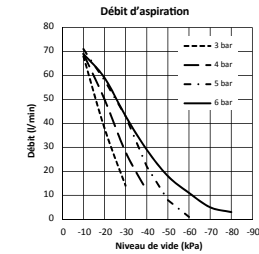
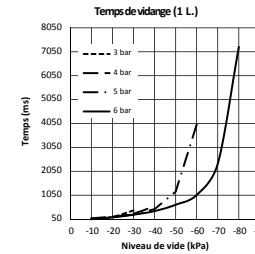
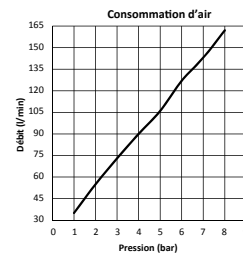
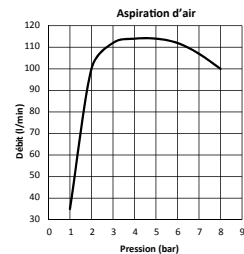
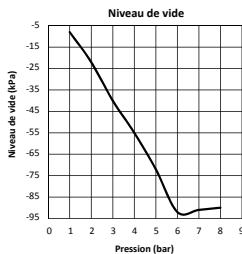
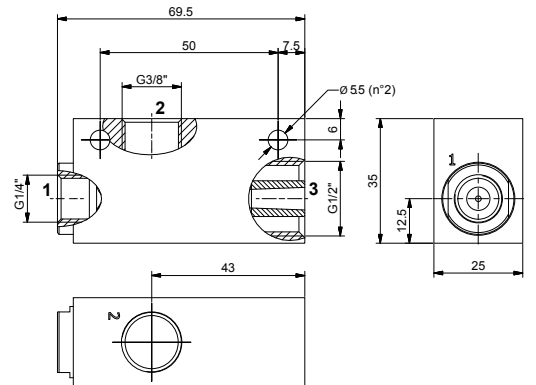
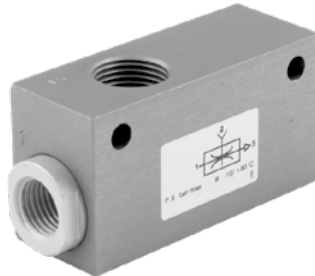

Caractéristiques			
Pression alimentation (bar)	2	4	6
Niveau de vide (Kpa)	-22	-55	-92
Capacité aspiration (l/min)	100	114	112
Consommation air (l/min)	55	90	127

Caractéristiques	
Fluide	air filtré non lubrifié
Pression (bar)	1 à 8
Température (°C)	-10 à +80
Poids (gr)	122

Générateurs de vide | SÉRIE YV

YV.38.M0.0106+S GÉNÉRATEUR DE VIDE MONO-ÉTAGÉ RACCORDEMENT G3/8" SILENCIEUX

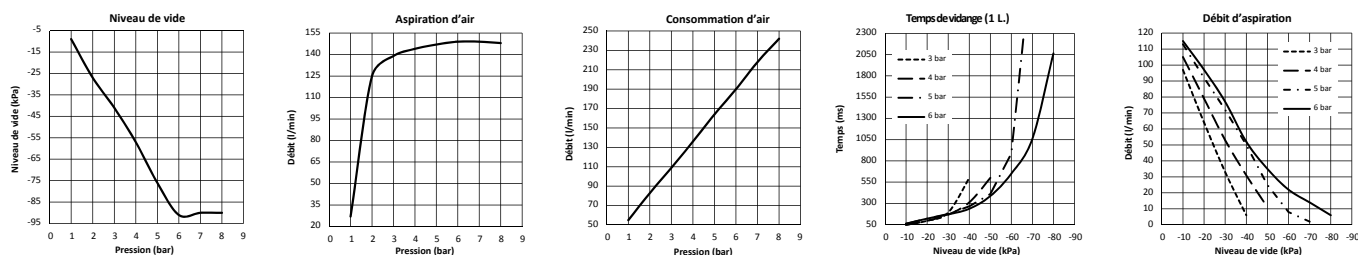
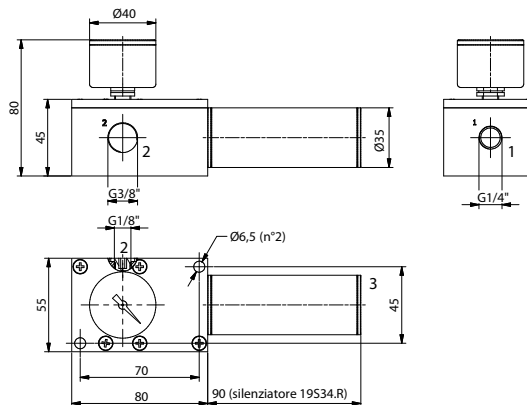
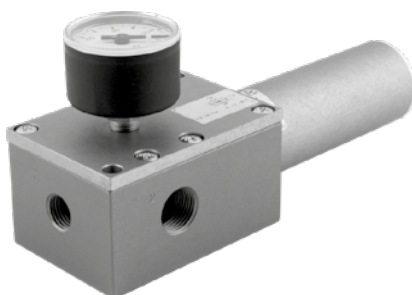

Caractéristiques				Caractéristiques	
Pression alimentation (bar)	2	4	6	Fluide	air filtré non lubrifié
Niveau de vide (Kpa)	-27	-57	-91	Pression (bar)	1 à 8
Capacité aspiration (l/min)	125	144	149	Température (°C)	-10 à +80
Consommation air (l/min)	83	136	190	Poids (gr)	450

YV.06.MT.0010 GÉNÉRATEUR DE VIDE MONO-ÉTAGÉ EN T RACCORDEMENT Ø6

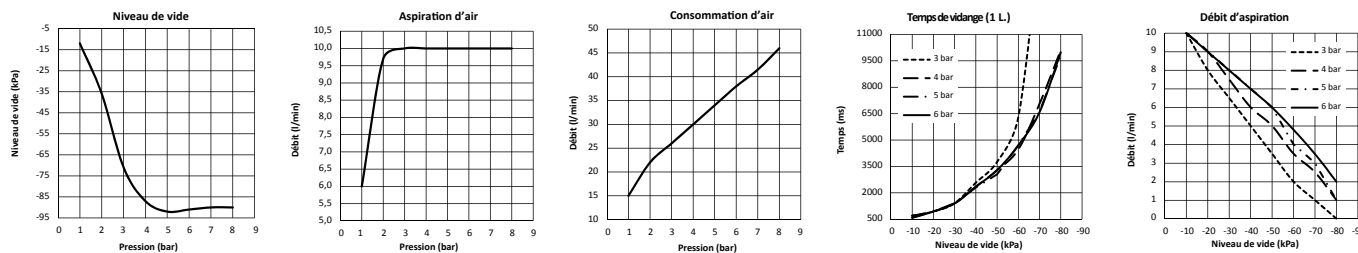
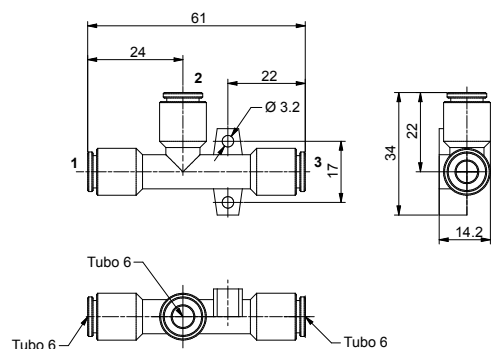

Caractéristiques				Caractéristiques	
Pression alimentation (bar)	2	4	6	Fluide	air filtré non lubrifié
Niveau de vide (Kpa)	-36	-87	-91	Pression (bar)	1 à 8
Capacité aspiration (l/min)	10	10	10	Température (°C)	-10 à +80
Consommation air (l/min)	22	30	38	Poids (gr)	12

Générateurs de vide | SÉRIE YV

YV.18.MT.0010

GÉNÉRATEUR DE VIDE MONO-ÉTAGÉ EN T
RACCORDEMENT G1/8"
CONTRE-SOUFFLAGE

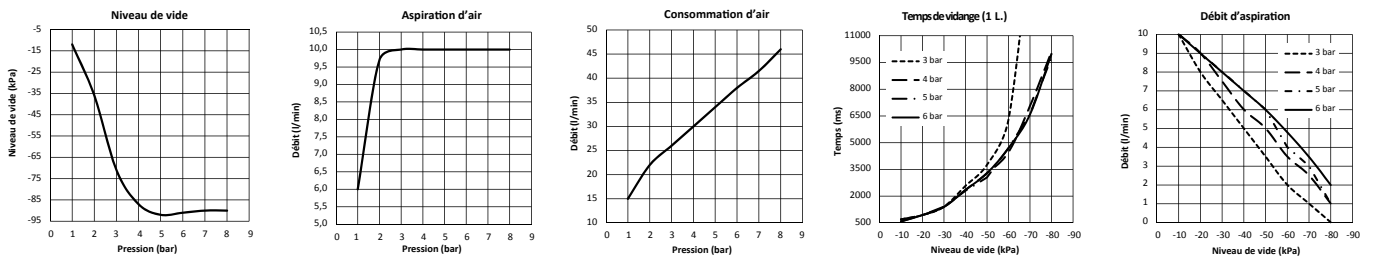
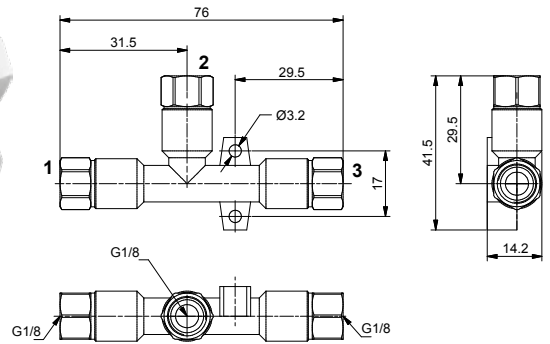
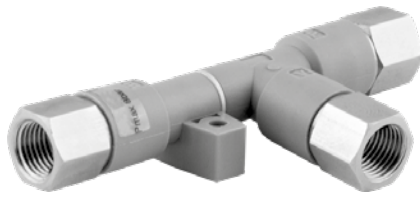

Caractéristiques			
Pression alimentation (bar)	2	4	6
Niveau de vide (Kpa)	-36	-87	-91
Capacité aspiration (l/min)	10	10	10
Consommation air (l/min)	22	30	38

Caractéristiques	
Fluide	air filtré non lubrifié
Pression (bar)	1 à 8
Température (°C)	-10 à +80
Poids (gr)	36

YV.10.MT.0038

GÉNÉRATEUR DE VIDE MONO-ÉTAGÉ EN T
RACCORDEMENT G3/8"

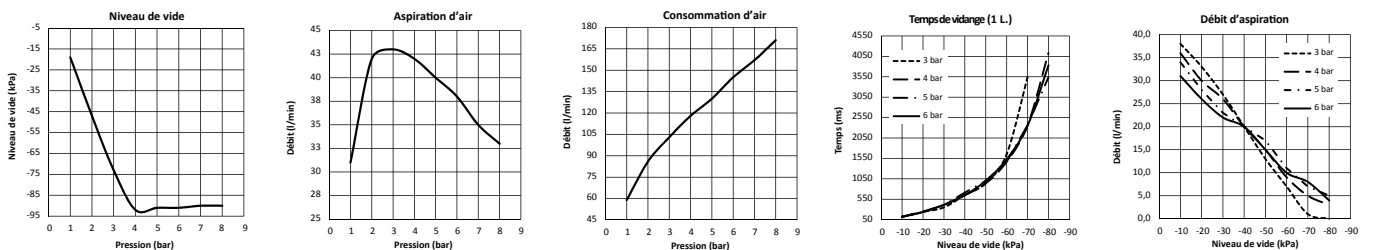
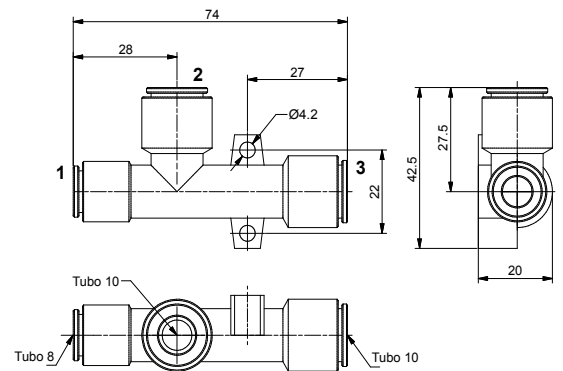
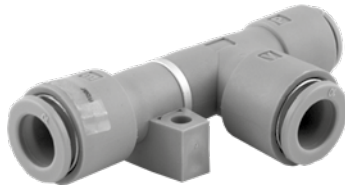

Caractéristiques			
Pression alimentation (bar)	2	4	6
Niveau de vide (Kpa)	-47	-92	-91
Capacité aspiration (l/min)	42	42	38
Consommation air (l/min)	86	118	145

Caractéristiques	
Fluide	air filtré non lubrifié
Pression (bar)	1 à 8
Température (°C)	-10 à +80
Poids (gr)	25

Générateurs de vide | SÉRIE YV

YV.14.MT.0038

GÉNÉRATEUR DE VIDE MONO-ÉTAGÉ EN T
RACCORDEMENT G1/4"

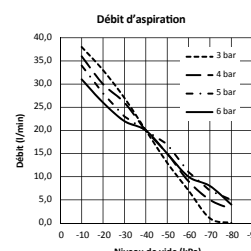
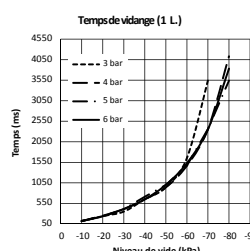
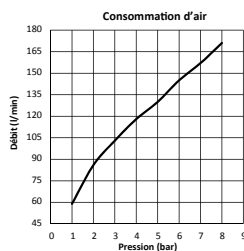
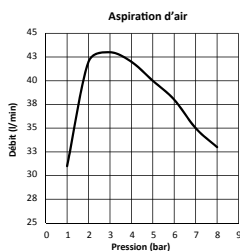
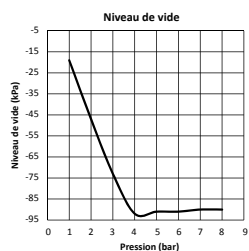
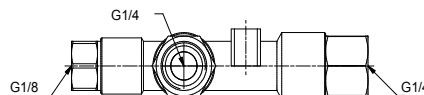
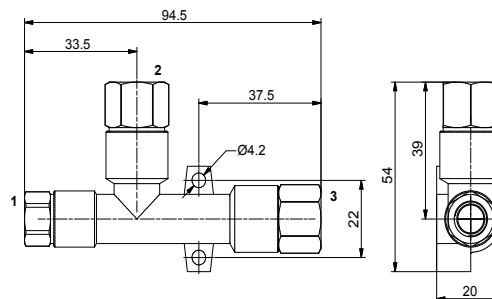

Caractéristiques			
Pression alimentation (bar)	2	4	6
Niveau de vide (Kpa)	-47	-92	-91
Capacité aspiration (l/min)	42	42	38
Consommation air (l/min)	86	118	145

Caractéristiques	
Fluide	air filtré non lubrifié
Pression (bar)	1 à 8
Température (°C)	-10 à +80
Poids (gr)	86

YV.14.MU.0038

GÉNÉRATEUR DE VIDE MULTI-ÉTAGÉ
RACCORDEMENT G1/4"

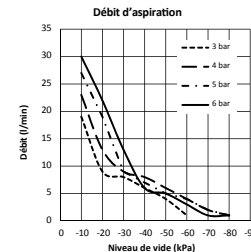
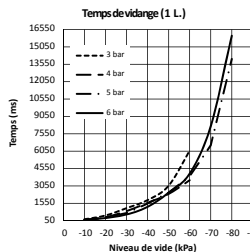
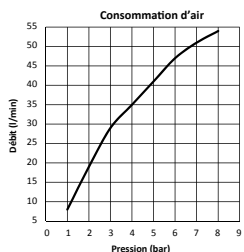
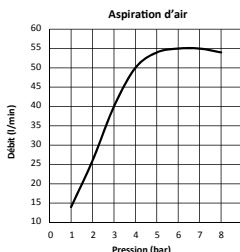
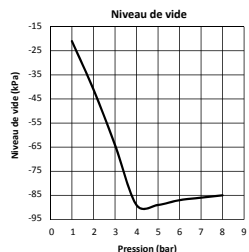
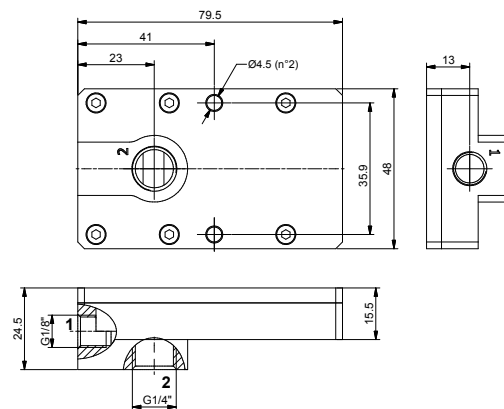

Caractéristiques			
Pression alimentation (bar)	2	4	6
Niveau de vide (Kpa)	-41	-89	-87
Capacité aspiration (l/min)	26	50	55
Consommation air (l/min)	19	35	47

Caractéristiques	
Fluide	air filtré non lubrifié
Pression (bar)	1 à 8
Température (°C)	-10 à +80
Poids (gr)	130

Générateurs de vide | SÉRIE YV

YV.38.MU.0062

GÉNÉRATEUR DE VIDE MULTI-ÉTAGÉ
RACCORDEMENT G3/8"

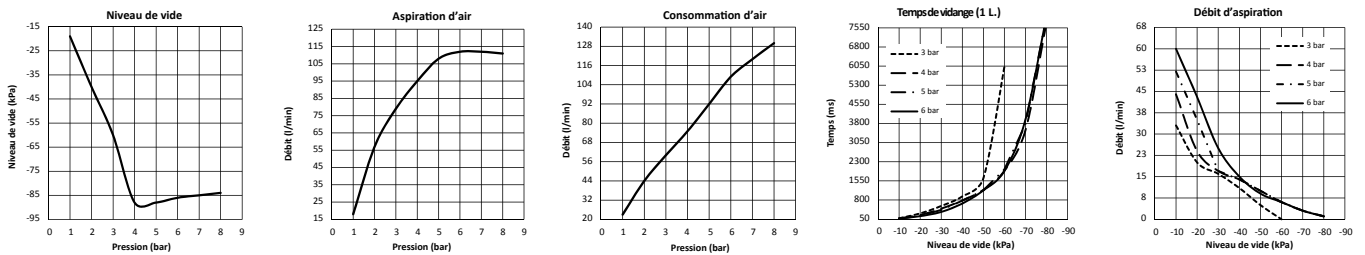
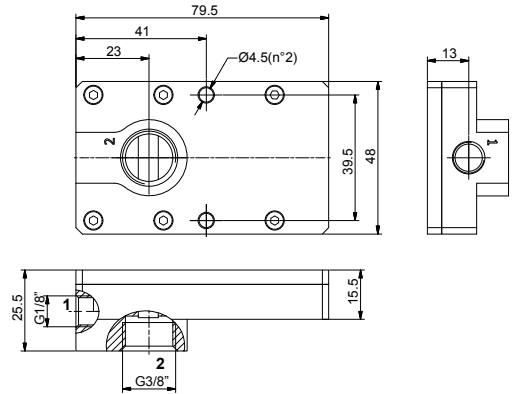

Caractéristiques				Caractéristiques	
Pression alimentation (bar)	2	4	6	Fluide	air filtré non lubrifié
Niveau de vide (Kpa)	-40	-88	-86	Pression (bar)	1 à 8
Capacité aspiration (l/min)	57	95	112	Température (°C)	-10 à +80
Consommation air (l/min)	44	75	109	Poids (gr)	132

YV.38.MU.0077

GÉNÉRATEUR DE VIDE MULTI-ÉTAGÉ
RACCORDEMENT G3/8"

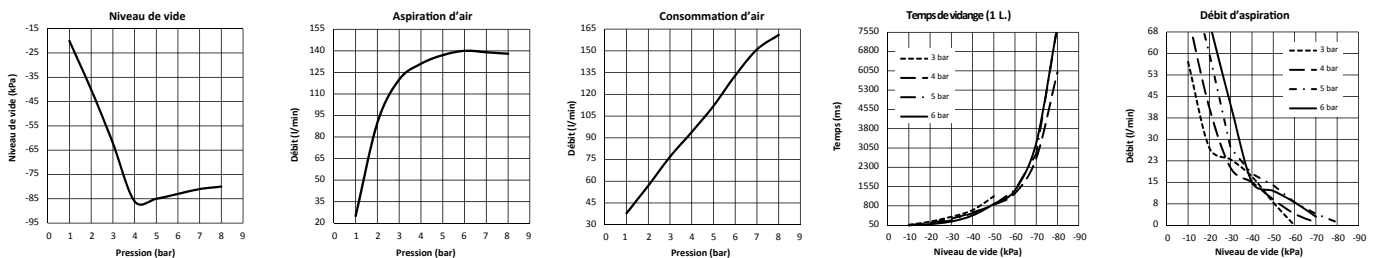
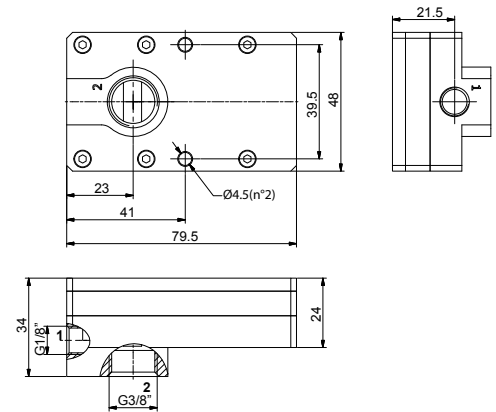

Caractéristiques				Caractéristiques	
Pression alimentation (bar)	2	4	6	Fluide	air filtré non lubrifié
Niveau de vide (Kpa)	-40	-86	-83	Pression (bar)	1 à 8
Capacité aspiration (l/min)	90	131	140	Température (°C)	-10 à +80
Consommation air (l/min)	57	94	133	Poids (gr)	178

Générateurs de vide | SÉRIE YV

YV.38.MU.0083

GÉNÉRATEUR DE VIDE MULTI-ÉTAGÉ
RACCORDEMENT G3/8"

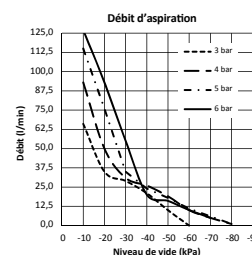
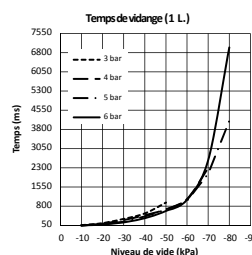
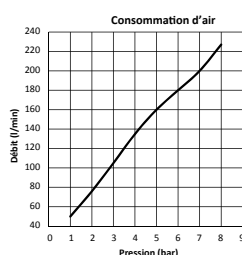
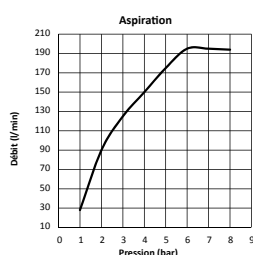
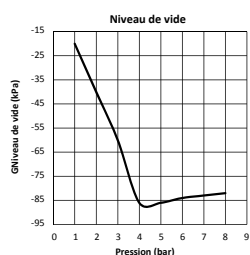
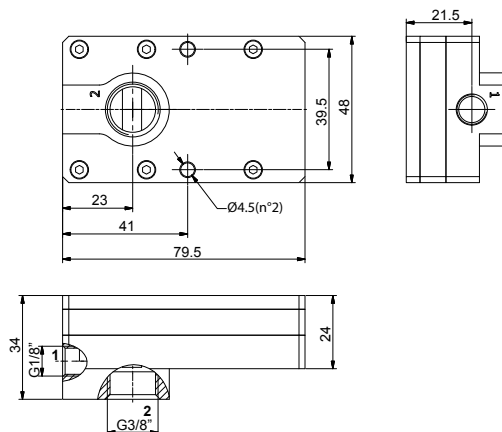

Caractéristiques			
Pression alimentation (bar)	2	4	6
Niveau de vide (Kpa)	-40	-86	-84
Capacité aspiration (l/min)	90	150	195
Consommation air (l/min)	76	135	180

Caractéristiques	
Fluide	air filtré non lubrifié
Pression (bar)	1 à 8
Température (°C)	-10 à +80
Poids (gr)	178

YS.38

SILENCIEUX G3/8"

YS.12

SILENCIEUX G1/2"

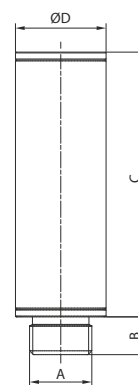

Référence	Description	A	B	C	± D	Poids
YS.38	G3/8"	G3/8"	10	70	24	35
YS.12	G1/2"	G1/2"	12	90	35	83

YF.38

FILTRE VERTICAL

RACCORDMENT G3/8"

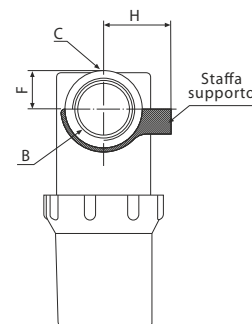
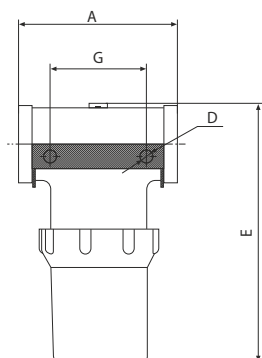

Référence	Description	A	B	C	D	E	F	G	H	Poids
Y.38	G3/8"	76	2-G3/8"	NPSF 1/8	2-Ø6,5	71,3	14	45	27	70

